

| MODEL #   | VOLUME MAIN (GAL) | VOLUME AGE (GAL) | WIDTH (DIM A) | LENGTH (DIM B) | HEIGHT (DIM C) | MATERIAL      |
|-----------|-------------------|------------------|---------------|----------------|----------------|---------------|
| BM-100-2  | 100               | 50               | 4'-6"         | 4'-6"          | 3'-6"          | POLYPROPYLENE |
| BM-250-2  | 250               | 125              | 6'-6"         | 6'-6"          | 4'-6"          | POLYPROPYLENE |
| BM-500-2  | 500               | 250              | 6'-6"         | 6'-6"          | 6'-0"          | POLYPROPYLENE |
| BM-750-2  | 750               | 375              | 6'-6"         | 6'-6"          | 8'-0"          | POLYPROPYLENE |
| BM-1000-2 | 1100              | 500              | 8'-6"         | 6'-6"          | 8'-6"          | POLYPROPYLENE |

- STANDARD ELECTRICAL POWER IS 208 VAC 3 $\phi$ .
- CONTACT FACTORY FOR LARGER SYSTEMS.

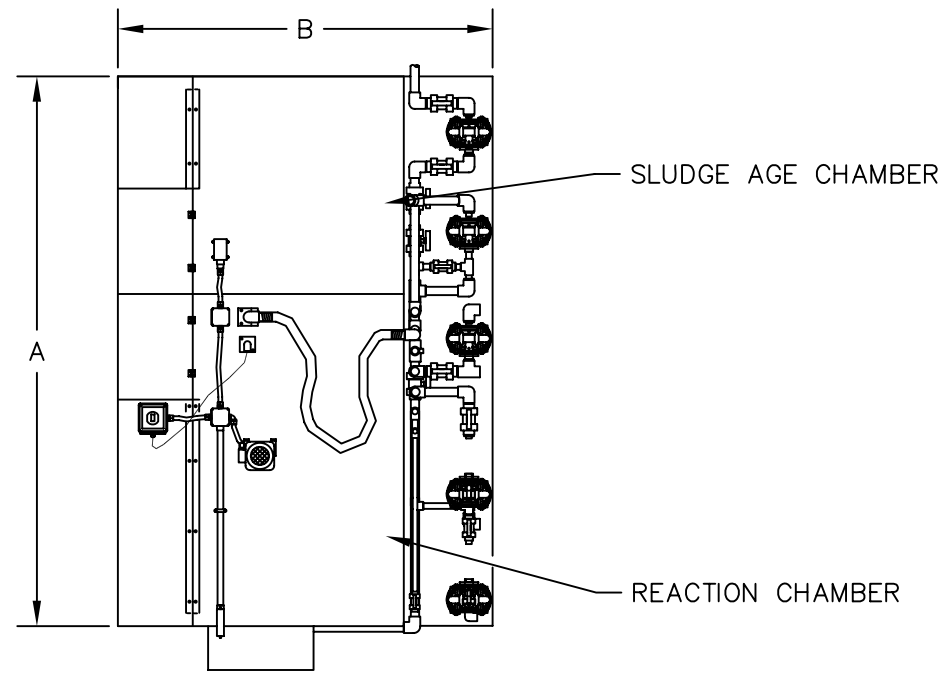

PLAN VIEW

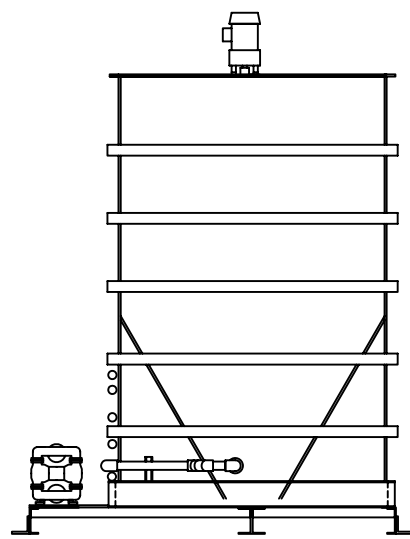

REAR ELEVATION

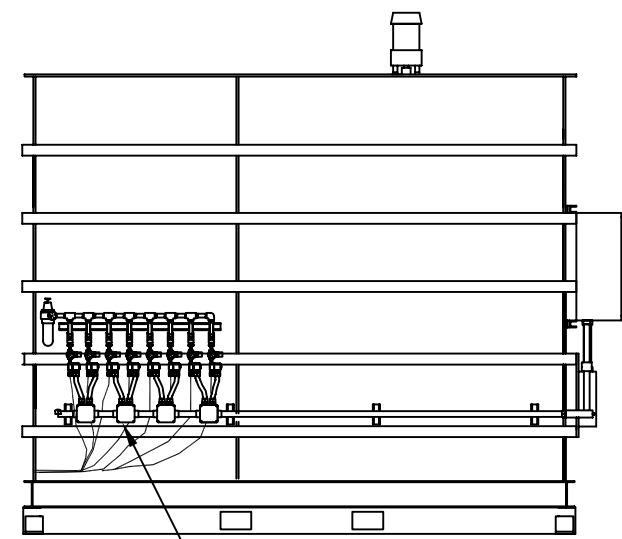

LEFT ELEVATION

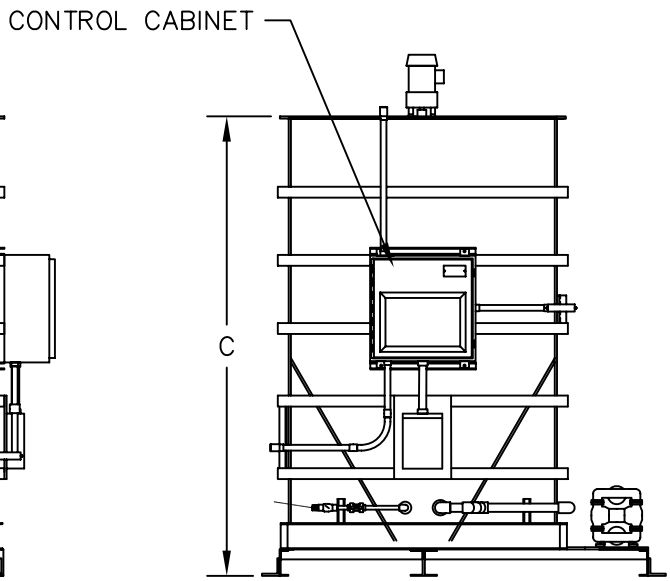

FRONT ELEVATION

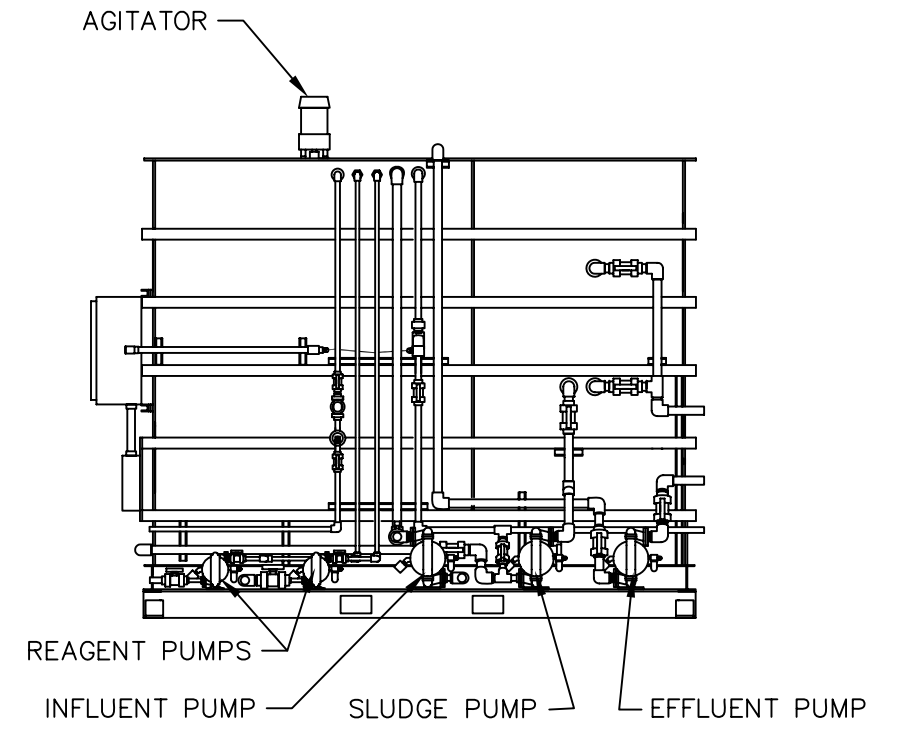

RIGHT ELEVATION

BATCH TREATMENT SYSTEM  
WITH INTEGRAL SLUDGE AGE TANK

[www.TSI-LLC.us](http://www.TSI-LLC.us)

**TSI TOTAL SYSTEMS INTERNATIONAL, LLC**  
 1256 Bretmoor Way  
 San Jose, CA 95129  
 USA  
 Phone: 1-408-996-0447  
 Facsimile: 1-408-996-9480

|  |                  |              |              |
|--|------------------|--------------|--------------|
| EQUIPMENT CUT SHEET  |                  |              |              |
| BATCH TREATMENT SYSTEM WITH INTEGRAL SLUDGE AGE  |                  |              |              |
| PROPRIETARY INFORMATION: This document may not be used or copied without prior written permission of TSI |                  |              |              |
| FILENAME: TSI BM-2 CUT   | DATE: 12-16-1999 | DRAWN BY: DP | CHECKED BY:  |
| DRAWING NUMBER: BM-2 CUT   | SCALE: NONE      | SIZE: D      | SHEET 1 OF 1 |